

LiberoPro

LiberoPro Point for 2 1PH Units, 1 refrigerated drawer - UK Plugs

ITEM # _____

MODEL # _____

NAME # _____

SIS # _____

AIA # _____



351090 (E2VVADBRZU)

* NOT TRANSLATED *

Main Features

- Can be combined with up to two tabletop appliances LiberoPro 1PHASE (Plug Type UK): flat induction hobs, induction wok, induction griddle.
- Compact, lightweight and easy to move.
- Plate holder shelf coupled with tempered glass and lighting for a better visibility from guest side.
- Designed for LiberoPro Duo function for automatic regulation of fan speed according to cooking intensity. Can be activated exclusively with LiberoPro stand alone units.
- LiberoPro Fresh is a low noise air filtration system to absorb efficiently grease particles and bad odours in the working area. It is a 2-stage filtering system with stainless steel fat filters and ceramic activated carbon ones.
- Integrated stainless steel refrigerated drawer with temperature regulation between 0°C and +10°C. No drain required.
- 37 lt refrigerated drawer capacity accepting N° 1 GN1/1 + N° 1 GN 2/4 trays.
- 30 lt neutral drawer - accepting N° 1 GN1/1 - is available as optional accessory.
- Through the user interface with soft touch buttons the operator can: -vary the 4 fan speed; -switch on the LED lighting system of the cooking area; -set the temperature of the refrigerated drawer; -display indications on maintenance operations (e.g. on filters) or any anomalous operating conditions.

Construction

- Heavy duty AISI 304 Stainless steel construction.
- Mounted on 4 swivelling wheels with brakes on the 2 front wheels (on the operator side).
- Frontal panel in AISI 304 can be customized requiring a special execution.
- Grease and odours filters are easily accessible and removable from operator's side for efficient maintenance without any tool.
- Side support frames each holding n.2 GN 1/9 containers and n.1 tools holder. All included in the standard delivery and easily removable for better cleanability.
- Plug type: IEC/EN 60309-1/2 - 32 amps.
- IPX4 water resistance certification.

Included Accessories

- 2 of - NOT TRANSLATED - PNC 650190
- 2 of - NOT TRANSLATED - PNC 650191
- 1 of - NOT TRANSLATED - PNC 650192
- 1 of - NOT TRANSLATED - PNC 650193

Optional Accessories

- Tilting side shelf for Libero Point PNC 650005
- - NOT TRANSLATED - PNC 650189
- - NOT TRANSLATED - PNC 650190
- - NOT TRANSLATED - PNC 650191
- - NOT TRANSLATED - PNC 650192

APPROVAL: _____



- - NOT TRANSLATED - PNC 650193
- - NOT TRANSLATED - PNC 650194
- - NOT TRANSLATED - PNC 650195
- - NOT TRANSLATED - PNC 651003

Front

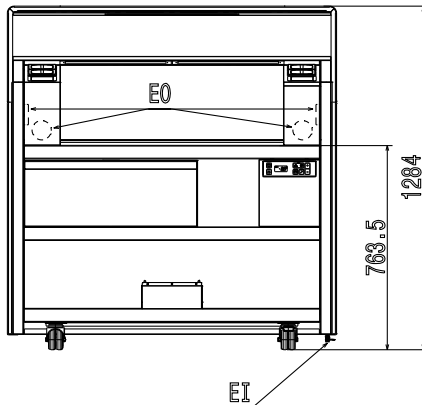

Side

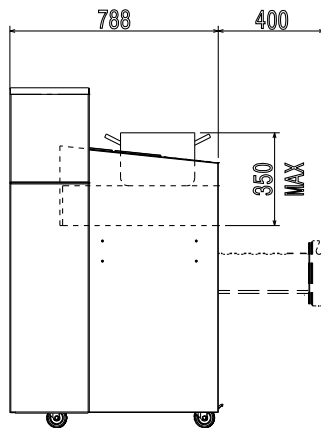

EI = Electrical inlet (power)
 EO = Electrical Outlet

Top

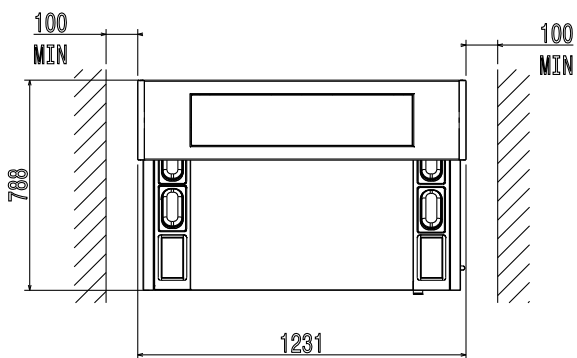

Electric

Supply voltage:

351090 (E2VVADBRZU)

Electrical power max.:

Plug type:

380-415/380-400 V/3N
 ph/50/60 Hz

12.5 kW

IEC/EN 60309-1/2

Key Information:

External dimensions, Width: 1231 mm

External dimensions, Depth: 788 mm

External dimensions, Height: 1284 mm

Net weight: 180 kg

Frontal power sockets available for Plug-in Units: 4 x 1 Phase Plugs (Plug Type 13A-UK)

Sustainability

Refrigerant type: R600a